

USER GUIDE  
UGC023/0305

# Access Loader

Models AL2 and AL5



**INTRODUCTION** • Purpose of the User Guide • How the guide is organized • Your responsibilities as a user • **ATTENTION:** Read this so no one gets hurt • **DESCRIPTION** • What is the Access Loader? • Typical applications • How it work  
• Specifications: Access Loader • **INSTALLATION** • Unpacking the boxes • Preparing for installation • Mounting the  
Access Loader • Completing the Loader Installations • Electrical Installations • Changing the Loader's Inlet Orientation  
• Changing the Loader's Lid Hinge Location • Installing Ratio Valves • **OPERATION** • Control Overview • Control  
Overview • Loader Operation • Operating Modes • Setting Feed Tubes • Sensor Adjustments

Please record your equipment's model and serial number(s) and the date you received it in the spaces provided.

It's a good idea to record the model and serial number(s) of your equipment and the date you received it in the User Guide. Our service department uses this information, along with the manual number, to provide help for the specific equipment you installed.

Please keep this User Guide and all manuals, engineering prints and parts lists together for documentation of your equipment.

Date:

---

Manual Number: UGC023/0305

---

Serial Number(s):

---

Model Number(s):

---

**DISCLAIMER:** The Conair Group, Inc., shall not be liable for errors contained in this User Guide or for incidental, consequential damages in connection with the furnishing, performance or use of this information. Conair makes no warranty of any kind with regard to this information, including, but not limited to the implied warranties of merchantability and fitness for a particular purpose.

# Table of Contents

## 1-1 Introduction

Purpose of the user guide . . . . .	1-2
How the guide is organized . . . . .	1-2
Your responsibilities as a user . . . . .	1-3
ATTENTION: Read this so no one gets hurt . . . . .	1-4

## 2-1 Description

What is the Access Loader? . . . . .	2-2
Typical applications . . . . .	2-2
How it works . . . . .	2-4
Specifications: Access Loader . . . . .	2-6

## 3-1 Installation

Unpacking the boxes . . . . .	3-2
Preparing for installation . . . . .	3-3
Mounting the Access Hopper Loader . . . . .	3-5
Installing Ratio Valves . . . . .	3-6
Completing the Loader Installations . . . . .	3-7
Electrical Installations . . . . .	3-9
Changing the Loader's Material Inlet Orientation . . . . .	3-9
Changing the Loader's Lid Hinge Location . . . . .	3-11
Connecting a Remote Demand Sensor . . . . .	3-12
Connecting a Remote on/off Switch . . . . .	3-13
Installing a Fill Switch . . . . .	3-13
Adding a Pneumatic Solenoid to the Terminal Box . . . . .	3-14

## **4-1** Operation

Control Overview . . . . .	4-2
Accessing Control Functions . . . . .	4-2
Control Security . . . . .	4-3
Alarm Messages . . . . .	4-5
Loader Operation . . . . .	4-4
Operating Modes . . . . .	4-5
Types of Feed Tubes . . . . .	4-8
Sensor Adjustments . . . . .	4-9

## **5-1** Maintenance

Conveying Filter Cleaning . . . . .	5-2
Motor Brush Checking/Replacing . . . . .	5-4
Brushless Motor Filter Cleaning/Replacing . . . . .	5-6

## **6-1** Troubleshooting

Before beginning . . . . .	6-2
A few words of caution . . . . .	6-2
Conveying Problems . . . . .	6-3

## **A** Appendix

We're here to help . . . . .	A-2
How to contact customer service . . . . .	A-2
Before you call... . . . . .	A-2
Equipment guarantee . . . . .	A-3
Performance warranty . . . . .	A-3
Remote Demand Sensor kit with Demand Selector Switch . . . . .	A-4
Remote Demand Sensor kit with Demand Selector Switch Wiring Instructions . . . . .	A-5
Remote Demand on/off kit . . . . .	A-6
Remote Demand on/off Wiring Instructions . . . . .	A-7

# Introduction

---

Purpose of the user guide. . . . . 1-2

How the guide is organized. . . . . 1-2

Your responsibilities as a user. . . . . 1-3

ATTENTION:

    Read this so no one gets hurt . . . . . 1-4

## Purpose of the User Guide

This User Guide describes the Conair Access Loader and explains step-by-step how to install, operate, maintain and repair this equipment.

Before installing this product, please take a few moments to read the User Guide and review the diagrams and safety information in the instruction packet. You also should review manuals covering associated equipment in your system. This review won't take long, and it could save you valuable installation and operating time later.

## How the Guide is Organized

Symbols have been used to help organize the User Guide and call your attention to important information regarding safe installation and operation.



Symbols within triangles warn of conditions that could be hazardous to users or could damage equipment. Read and take precautions before proceeding.

- 1** Numbers indicate tasks or steps to be performed by the user.
- ◆ A diamond indicates the equipment's response to an action performed by the user.
- ☐ An open box marks items in a checklist.
- A circle marks items in a list.
- ◆ Indicates a tip. A tip is used to provide you with a suggestion that will help you with the maintenance and the operation of this equipment.
-  Indicates a note. A note is used to provide additional information about the steps you are following throughout the manual.

## Your Responsibility as a User

You must be familiar with all safety procedures concerning installation, operation and maintenance of this equipment. Responsible safety procedures include:

- Thorough review of this User Guide, paying particular attention to hazard warnings, appendices and related diagrams.
- Thorough review of the equipment itself, with careful attention to voltage sources, intended use and warning labels.
- Thorough review of instruction manuals for associated equipment.
- Step-by-step adherence to instructions outlined in this User Guide.

## ATTENTION:

### Read this so no one gets hurt

We design equipment with the user's safety in mind. You can avoid the potential hazards identified on this machine by following the procedures outlined below and elsewhere in the User Guide.



**WARNING: Improper installation, operation, or servicing may result in equipment damage or personal injury.**

This equipment should be installed, adjusted, and serviced by qualified technical personnel who are familiar with the construction, operation, and potential hazards of this type of machine.

All wiring, disconnects, and fuses should be installed by qualified electrical technicians in accordance with electrical codes in your region. Always maintain a safe ground. Do not operate the equipment at power levels other than what is specified on the machine serial tag and data plate.



**WARNING: Voltage hazard**

This equipment is powered by three-phase alternating current, as specified on the machine serial tag and data plate.

A properly sized conductive ground wire from the incoming power supply must be connected to the chassis ground terminal inside the electrical enclosure. Improper grounding can result in severe personal injury and erratic machine operation.

Always disconnect and lock out the incoming main power source before opening the electrical enclosure or performing non-standard operating procedures, such as routine maintenance. Only qualified personnel should perform troubleshooting procedures that require access to the electrical enclosure while power is on.



## Description

---

What is the Access Loader? . . . . .	2-2
Typical applications. . . . .	2-2
How it works . . . . .	2-3
Specifications: Access Loader . . . . .	2-5

## What is the Access Loader?

The Access model Self-contained vacuum loader is a plastic material transfer device designed to vacuum convey raw plastic material pellets and/or regrind over short distances. It incorporates a vacuum motor to create the energy necessary for the material transfer process, plus a logic controller, with timers to coordinate all functions. A filter to separate conveyed material from the conveying air stream is included to protect the vacuum motor and keep air around the loader clean. A filter cleaning solenoid valve is also included to lengthen the operational life of the filter between servicing. Compressed air is required for the filter cleaning action and some optional functions, like Ratio loading.

## Typical Applications

Access Self-contained vacuum loaders are typically used in two main ways; Hopper loading and Direct feed.

**Hopper Loading:** The loader is mounted directly above whatever vessel needs to be filled and to be kept full. The Access vacuum chamber is filled by its vacuum motor and then a discharge flapper at the bottom opens, by gravity at the conclusion of loading to release the loaded material into the receiving vessel. A demand level switch, triggered by the position of the discharge flapper indicates the need for more loading or not.

**Direct Feed:** The loader is mounted to a glass or metal hopper that is mounted to the throat of a plastic processing machine (IE: injection molder or extruder). A sensor on the hopper indicates the need for material. Material gravity flows out of the hopper and into the processing machine via the drain hole in the bottom.

The Access loader may also be used to unload vessels, like granulators, gaylords or barrels.

## How it Works

### The loading cycle:

A demand for material below the loader is created by either a reed-type switch that is magnetically triggered by the position of the discharge flapper on the bottom of the hopper loader model or by a sensor located remotely. This demand signal starts the loading cycle, all portions of the loading cycle and all other functions are displayed on the control, which governs all aspects of the loader's operation.

The demand signal starts the vacuum motor and allows the loader's vacuum chamber to create a negative draw on the material inlet line. This vacuum creates a flow of air that starts in the material inlet tube and allows plastic material to travel in the tube, with the air, into the loader. Once inside the loader, the air is drawn into the vacuum motor's fan housing after it passes through a round cloth filter located directly below the motor's air inlet. This filter keeps the plastic material in the loader's vacuum chamber but allows the air to pass through. This filtration not only keeps the material in the loader, protects the vacuum motor from the plastics material and keeps material dust from becoming air-borne after it passes through the motor. The vacuum motor remains on for the length of time set on the control.

### The unloading cycle:

Once the loading cycle concludes, the vacuum motor turns off and the loader enters the unloading portion of the cycle. While there is no vacuum pull on the loader from the motor, the material in the loader is allowed to drop by gravity from the bottom of the loader, into the receiving vessel the loader is mounted upon.



## **How It Works** (continued)

### **The filter cleaning cycle:**

During the unloading cycle, the blowback cycle occurs, directing blasts of compressed air through the filter from above, cleaning off collected plastic dust and material that may have become stuck to the filter during loading. The multiple blasts take advantage of the 'shock wave' effect for filter shaking and cleaning. At the conclusion of this discharge blowback cycle, a counterweight on the flapper causes it to return to the closed position.

Once blowback and the unloading portion of the loader operation are complete, the loader may begin loading again, as soon as the control determines there is another demand input. If no demand signal is received, then the loader waits in the “ready” mode.

### **The ratio loading cycle (optional):**

A popular option for the Access self contained loader is a ratio valve to allow the user to use the Access loader for conveying two materials, virgin and regrind. This option is typically used to reload granulated material from a granulator or vessel into a processing machine while virgin material is being loaded. This simple valve device works during the loading cycle and is controlled by the loader control. Loading times for the two materials may be independently set on the loader control so that approximate portions of each material can be transferred during loading. In addition, each of these portions may be programmed to occur several times during the loading cycle, if desired, so that there is a layering of the materials in the loader's vacuum chamber, to encourage a mixing as the materials flow out of the loader at the conclusion of loading. As the vacuum loading cycle operates, each inlet of the ratio valve alternately opens and closes in response to the control settings. As each inlet opens, vacuum flows through that line and allows virgin or regrind to flow to the loader. Then the other inlet opens, allowing that line to draw material through it. This sequence occurs until the loader's load time setting expires.

# Specifications

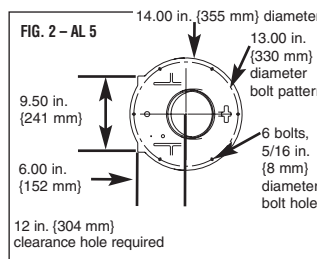
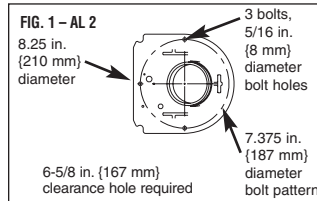
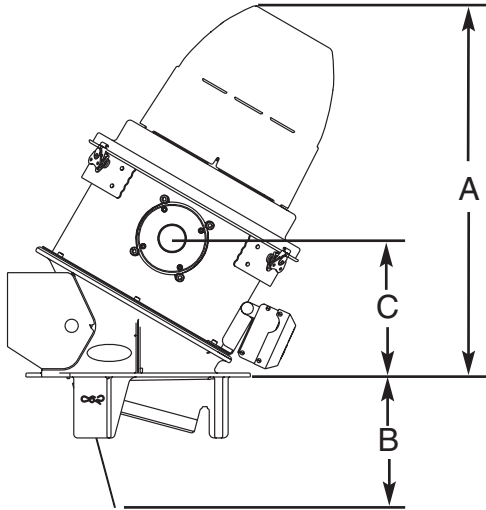

Loader model	AL 2	AL 5	AL 5
Loader volume ft <sup>3</sup> (liters)	0.2 (6.0)	0.5 (14.0)	
Loader Body Diameter inches (mm)	8 (203)	12 (304)	
Vacuum Motor	5/8 Hp - 2 Brush	7/8 Hp - 4 Brush	1.3 Hp - Brushless
Nominal throughput* lbs/hr (kg/hr)	100 (45)	500 (227)	1000 (454)
Maximum conveying distance ft (m)	50 (15.24)	75 (22.86)	120 (36.58)
Loader diameter inches (mm)	8 (203)	12 (304)	
Discharge type	Gravity flapper or Positive Discharge		
Demand sensor	integrated reed switch / remote capacitance sensor (optional)		
Dimensions inches (mm)			
A - Height above mounting plate†	20.77 (527.56)	23.17 (588.52)	
B - Depth below mounting plate	5.12 (130.04)	8.12 (206.25)	
with positive discharge	10 (254)	16 (406)	
C - Height to center of material inlet	8.77 (222.76)	8.64 (219.46)	
Mounting details	See FIG. 1		See FIG. 2
Installed weight lb (kg)	27.6 (12.52)	49 (22.22)	
Shipping weight lb (kg)	50 (22.68)	65 (29.48)	

## SPECIFICATION NOTES

\* Throughputs beyond the recommended ratings should not be attempted unless you are conveying virgin material from close distances. Higher throughputs could result in shortened brush and/or filter life. For higher throughputs, consult Conair for a quote on central vacuum loaders.

All Access Loaders are shipped with 10 ft. (3.048 m) of flexhose and a vertical feed tube.

Specifications can change without notice. Contact your Conair representative for the most current information.



# Installation

---

Unpacking the boxes . . . . .	3-2
Preparing for installation . . . . .	3-3
Mounting the Access Hopper Loader . . . . .	3-5
Installing Ratio Valves . . . . .	3-6
Completing the Loader Installations . . . . .	3-7
Electrical Installations . . . . .	3-9
Changing the Loader's Material	
Inlet Orientation . . . . .	3-9
Changing the Loader's Lid Hinge Location . . . . .	3-11
Connecting a Remote Demand Sensor . . . . .	3-12
Connecting a Remote on/off Switch . . . . .	3-13
Installing a Fill Switch . . . . .	3-13
Adding a Pneumatic Solenoid to the	
Terminal Box . . . . .	3-14

## Unpacking the Boxes

The Access self-contained vacuum loader comes in one to 3 boxes, depending upon the model and options selected. The loader will be shipped in one large box and accessories like feed tubes and ratio valves will be shipped in their own, smaller boxes.

 **Note:** Your particular loader may be packaged in with other equipment crates or boxes or may also have equipment packaged in with it, to conserve shipping space.

- 1 Carefully remove the loader and other components** from their boxes. Do not use wires or hoses as handles to lift heavy components. Once removed from the box, the loader may be set on a firm, flat surface with the motor towards the top. Note that the loader's upper portion is angled for easy access once in operation, but its three-legged, cast base may be safely set on a flat surface, as long as the discharge flapper valve is not open.
- 2 Remove all tape and other packing materials** from the loader and accessories. Take special note of tape that typically holds the discharge flapper closed. The loader will not work with this tape in place and it should be removed.
- 3 Carefully inspect all components** to make sure no damage occurred during shipping, and that you have all the necessary hardware.
- 4 Take a moment to record serial numbers** and electrical power specifications in the blanks provided on the back of the the User Guide's title page. The information will be helpful if you ever need service or parts.

## Preparing for Installation

Hopper-mounted Access loaders may be installed on any vessel with a flat top surface and as long as the lid and vessel are strong enough to support the weight of the loader and have mounting provisions such as bolt holes or hold down clamps (*see Section 2, "Specifications"*). Direct Feed Access loaders are designed to mount directly to the throat of a processing machine and the base of the throat mounted hopper assembly may be centered and match-drilled to the bolt hole pattern of the processing machine throat.

- 1 Prepare the electrical supply.** Access self-contained loaders require a single phase electrical supply (120 Volts AC or 220 Volts AC) as listed on the name plate and in the specifications page of this manual *See Section 2, "Specifications"*. Typically, it is best to provide an isolated circuit so that the operation of the loader does not effect, nor is effected by other equipment on the same circuit. The receptacle providing this supply must be within the reach of the loader's power cord. If a brushless motor is used,



## Preparing for Installation (continued)

The brushless motor option, because of its higher horsepower rating and greater conveying power, requires special electrical considerations. Twenty (20) amp power must be provided directly to the motor via its own power cable. The motor is also equipped with a small green plug that is connected to the terminal box of the loader.

With this arrangement, higher amperage power is connected directly to the motor and the small plug allows this power to be turned on and off in response to the needs of the Access Loader control. The junction box of the brushless motor also contains an auxiliary receptacle that provides a place where the Loader control may be plugged in for convenience or the control may be plugged in separately as desired. The convenience receptacle should not be used for any other equipment or appliances, besides the loader control.

Separate circuit breaker protection is provided in the top of the brushless motor junction box to protection is provided in the top of the brushless motor junction box to protect the motor circuit and the convenience receptacle.

- 2 Prepare the compressed air supply.** An air supply line will be plumbed to the solenoid located on the lid of the loader and a quick disconnect fitting is recommended for easy service. A 3/8" NPT female inlet is provided. If the air supply is not clean and dry, filtering devices must also be installed since the loader's filter cleaning function relies on clean and dry compressed air. Moisture traps and other air cleaning devices are best mounted away from the loader, but within easy service reach.
- 3 Determine location of control.** The Access loader's control may remain mounted to the loader or be remote mounted to a convenient location. When mounted on the loader, no further work is required. If mounted remotely, a quick-disconnect, remote control cable between the control and the loader must be installed and may have been shipped with the loader. If not, one is available from the Conair Parts Department. Assure that your desired control location is within the length of the remote control cable and the control can now be removed from the loader in preparation for being mounted in its remote location by removing the mounting bolts at the base of the loader's mounting bracket and unplugging the control cable from the terminal box of the loader. The control is mounted on a tiltable bracket and may be swung up to facilitate removal of the bracket or the control may be removed from the mounting bracket by removing the two side bolts at the hinge point. Once removed, replace the bolts in the flange of the loader body.



**WARNING:** You are responsible for the structural integrity of this installation.

## Preparing for Installation (continued)

Adjustable control MLC6 control mounting bracket allows control to pivot up for use at loader and down for viewing control from floor level. Bracket is also used for remote mounting of control.

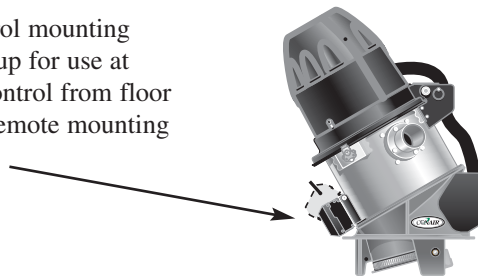

 **NOTE:** If your mounting surface does not match the standard bolt patterns available, you will need an adapter. You can make an adapter using the dimensions provided or purchase one from Conair.

- 4 Determine the orientation of the loader.** The Access loader provides superior accessibility for service and should be oriented for easiest service and access to the control. The material inlet and even the loader hinge may be relocated as required, once orientation is determined. Assure that enough room above and to the side of the loader is available for the hinged lid to open.
- 5 Prepare the mounting surface; Hopper loaders.** For Hopper Loaders, the Access loader discharge will fit down through an opening in the receiving hopper's lid and be held in place with either bolts that pass through match-drilled holes or hold-down clamps that are typically supplied on the top of Conair vessels like drying hoppers or blenders bins. See the specifications for the size of clearance hole required (*See Section 2, "Specifications"*) and/or bolt patterns for your model of loader. An adapter ring, available from Conair, may be required to reduce the size of an oversized hole to match the specific size of the loader being installed.
- 6 Prepare the mounting surface; Direct feed loaders.** For Direct feed loaders, assure that the processing machine throat is large enough to provide a suitable mounting surface for the loader and its glass or metal hopper. Measure the mounting bolt locations on the machine throat and assure that a suitable location in the base of the hopper may be drilled. Be sure the material passage hole in the bottom lines up with the processing machine throat and that no ledges will be created between the hopper assembly and the machine throat. If ledges will be present, an adapter plate with a tapered material opening may be required. An adapter plate may also facilitate the location of mounting holes if there is a mis-match between the base of the hopper and the machine throat.

## Preparing for Installation (continued)

- 7 Determine the location of conveying line(s).** Material conveying lines should be as straight and as short as possible. Multiple bends or loops in the hose or material conveying tubing should be avoided. If the Access loader material inlet does not accommodate the best path for the material line(s), the inlet may be moved and is described in (*See Section 3, “Changing the Loader’s Material Inlet Orientation”*).
- 8 Determine orientation of ratio valve (optional).** If a ratio valve is included with the loader, note the incoming material lines (virgin and regrind) will be at right angles to the material inlet of the loader. Note also that the inlets of the ratio valve may be oriented on opposite sides or the same side of the valve assembly, depending upon your needs. (*See Section 3, “Installing Ratio Valves”*).

## Mounting the Access Hopper Loader



**WARNING:** You are responsible for the structural integrity of this installation.

- 1 Safely lift the Access loader to the lid of the vessel.** First assure that the Access loader lid is closed and clamped securely.
- 2 Lift the loader into place and carefully place the three legged base down into the clearance hole of the vessel lid.** Rotate and orient as desired. The loader body’s “lean” should be in the direction of future service like filter cleaning and material change clean-outs and the control should be facing the same direction.
- 3 Secure the Access loader to the lid of the hopper.** If clamps are provided, swing them into position over the edge of the loader’s flange and tighten them. If nuts and bolts will be used, pass them through the vessel lid and through the mating holes in the mounting flange of the loader and secure them with lock-washers and nuts after applying thread-locking compound to prevent loss due to vibration. If possible, nuts welded to the underside of the vessel lid are preferred, to prevent any possibility of fastening hardware loosening and being lost into the vessel.

## Mounting the Access Direct Feed Loader

- 1 Match drill the base of the glass or metal hopper chamber.** Carefully measure the throat of the processing machine and match drill the base of the Access loader's hopper, assuring the large center hole of the base lines up with the feed throat opening of the processing machine. If the aluminum base will not allow passage of mounting bolts that line up with the processing machine throat bolts, an adapter plate might be required. If the material flow hole in the base of the hopper is larger than the processing machine throat, creating a ledge, an adapter plate with a tapered material flow hole might be required. To facilitate use of a drill press or machining center, the aluminum base or glass hoppers may be unbolted from the sight glass.
- 2 Mount the glass or metal hoppers to the processing machine throat.** Once the base is drilled, it may be mounted to the machine throat, for complete re-assembly once mounted. Mating surfaces between the hopper base, the adapter plate (if included) and the machine throat may be gasketed to minimize vacuum air leaks that can occur during vacuum conveying to the loader, but gasketing is not essential, since the Access loader is equipped with its own discharge flapper to isolate vacuum conveying air to the loading chamber of the loader.
- 3 Orient the loader on the hopper.** The loader portion of the direct feed assembly may be rotated to orient the loader in the best position for service and tubing routing.

 **NOTE:** With a Ratio Valve, the material inlet(s) will be 90 degrees from the orientation of the inlet of the loader. If this orientation will not be appropriate for your installation, consider reconfiguring the material inlet to another direction as described in Section 3, “Changing the Material Inlet Orientation”. If orientation is satisfactory, proceed to step two.

## Installing Ratio Valves

For Access loaders that are supplied with ratio valves, the valve may be shipped loose and needs to be mounted to the Access material inlet. For this purpose, the cast aluminum material inlet of the loader is provided without an inlet stub. When the valve is installed, it will provide the material inlet line(s) accordingly. To install the valve onto the inlet casting:

- 1 Assure that the Access loader is oriented as desired on the bin** that you will be loading and visually check the positioning of the valve on the inlet casting.
- 2 Check the orientation of the installed valve,** the valve itself may be re-oriented to allow the material to enter the valve as supplied, or 180 degrees from its supplied orientation. In the case of a ratio valve, the dual inlets may actually be re-oriented to enter from opposite directions, if desired. (*See Section 3, “Changing the Material Inlet Orientation”*) for instructions on changing the inlet orientation(s).

## Installing Ratio Valves (continued)



**WARNING:** You are responsible for the structural integrity of this installation.

- 3 The valve casting is supplied with a mounting flange** that mates with the inlet casting of the loader. Note that the inlet casting contains eight holes to allow mounting the valve in two different orientations, depending upon which side of the loader the inlet casting is located. Select the set of mounting holes that position the valve body upright, with the clean out cover on top horizontal.
- 4 Use the accompanying bolts to secure the valve casting to the inlet casting** with the included gasket in between the two mating surfaces.
- 5 Connect the compressed air hoses to the ratio valve.** The ratio solenoid inside the terminal box is equipped with two hoses, connected to ports “1” and “2”. The hose stemming from the port marked “2” should be connected to the “T” fitting on the bottom (regrind) cylinder. Port “1” on the solenoid should be connected to the “T” fitting on the top (virgin) cylinder. Route the hoses through the square hole in the top of the terminal box and remount the terminal box cover.

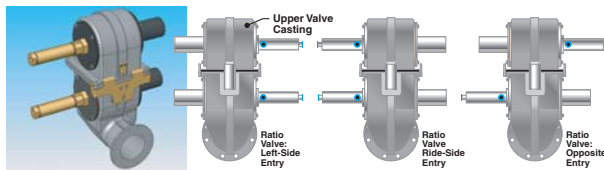

## Completing the Loader Installations

- 1 Install the conveying line; single material:** Connect the material conveying tubing to the loader by clamping one end of the flex hose around the inlet nipple of the loader. Route the hose carefully avoiding bends, loops, or droops and cut the hose to length and connect the included feed tube into the other end. Secure both connections with the included hose clamps. If orientation of the inlet needs to be changed, (See Section 3, “Changing the Material Inlet Orientation”)

## Completing the Loader Installations (continued)

- 2 Install the conveying lines; ratio loader:** If a ratio valve is included, it must be installed on the material inlet port of the loader with the provided bolts. Bolt the valve so that it is positioned as upright as possible with the material inlets (virgin and regrind) positioned as horizontal as possible. Note that the top section of the ratio valve may be easily removed and oriented to allow for the incoming materials to come from the same direction or two different directions. If orientation of the inlet needs to be changed to allow for better routing of the lines coming into the ratio valve, (*see Section 3, "Installing Ratio Valves"*). Once the valve is installed on the loader and orientation of the incoming lines are established, conveying tubing may be connected to the valve and secured with hose clamps. The other ends of the tubing may be connected to their appropriate feed tubes and secured with hose clamps, assuring that the tubing is routed and cut to length to take the most direct and shortest path. Be sure to connect the right tube to the right material source as marked on the valve inlets: V=Virgin, R=Regrind.
- 3 Connect compressed air to the loader:** The Access self-contained loader requires compressed air for filter cleaning and other optional functions like ratio loading. The compressed air supply line should be connected into the 3/8" NPT female fitting provide in or adjacent to the blowback solenoid on the lid of the loader. A quick disconnect fitting (that does not restrict air flow) is recommended.
- 4 Mount the remote control.** If the control is to be located away from the loader and has been removed from the loader, it may now be mounted to a horizontal surface using the same mounting bracket that held it to the loader. Be sure it is within the length of the cable provided for this purpose and that the cable is routed away from hot or moving parts. Use similar-sized bolts to hold the control in its new location.
- 5 Connect the loader control to the electrical supply.** Connect the loader into an appropriate and isolated 120 or 220 volt power source (depending upon loader voltage) following all applicable electrical codes for your area and your facility. If a brushless motor is used, see special connection instructions in *Section 5, "Brushless Motor Filter Cleaning/Replacing"*.

## Electrical Installation of Brushless Vacuum Motor Option

The brushless motor option, with its higher horsepower rating and greater conveying power, requires special electrical considerations. Twenty (20) amp power must be provided directly to the motor via its own power cable. The motor is also equipped with an extra cable that is wired into the terminal box of the loader. With this arrangement, higher amperage power is connected directly to the motor and the smaller wire allows this power to be turned on and off in response to the needs of the Access Loader control. The brushless motor is also equipped with a junction box, that provides a place where the Access Loader control may be plugged in for convenience or the control may be plugged in separately as desired. The convenience receptacle should not be used for any other equipment or appliances; only the loader control. Separate circuit breaker protection is provided in the top of the brushless motor junction box which protects the motor circuit and the convenience receptacle.

## Changing the Loader's Material Inlet Orientation

Access loaders are shipped with the material inlet located in the most logical orientation for most common conveying applications, but this inlet may be located in a variety of other places if it is more convenient for your installation. To perform this change, the stainless steel vacuum cylinder may be unbolted and rotated as desired to orient the inlet to the desired location around the perimeter of the cylinder.

- 1 Remove the lid and motor assembly** and unplug the vacuum motor.
- 2 Remove the DIN-type electrical connector** from the blowback solenoid by unscrewing the center bolt and pulling the connector off the solenoid.
- 3 Release the lid hold-down clamps** and pull the pin from the lid hinge to allow the entire lid and motor assembly to be lifted from the loader body.
- 4 Remove the cylinder mounting screws.** Located around the base of the loader's cylindrical body are 6 bolts that secure the cylinder to the cast base. Removing these screws frees the cylinder and allows it to be rotated to a new position.

## Changing the Loader's Material Inlet Orientation (continued)

- 5 Locate the inlet tube to the new location.** Re-orient the loader body to a new position and line up the mounting bolt holes.
- 6 Refasten the loader body and re-assemble the loader.** Firmly re-install the 6 bolts using the 10 mm wrench, tight enough to prevent vacuum leaks. Reinstall lid and reconnect solenoid and motor wires. See instructions below for re-orienting the lid's hinge, if necessary.

## Changing the Loader's Lid Hinge Location

Access loaders are shipped with the lid hinged in the logical direction for most common conveying applications and approximately opposite the material inlet. This orientation may be changed to a choice of other places if it is more convenient for your installation. The hinge and the lid clamps both use the same mounting, so you can locate the lid hinge wherever there is currently a clamp.

- 1 Remove the lid and motor assembly** and unplug the vacuum motor.
- 2 Remove the DIN-type electrical connector from the blowback solenoid** by unscrewing the center bolt and pulling the connector off the solenoid.
- 3 Release the lid hold-down clamps** and pull the pin from the lid hinge to allow the entire lid and motor assembly to be lifted from the loader body.



## Changing the Loader's Lid Hinge Location

- 4 Remove the lid clamp where you want the hinge to be located.** Carefully picture the motion of the lid, so that once the hinge is relocated, it's swing is not blocked by adjacent equipment, building structures, etc. The clamp is held by screws that are threaded into a backing plate, inside the clamp mount. The backing plate will fall out when the screws are removed.
- 5 Relocate the hinge bracket.** Two long screws, located in the side of the hinge bracket hold it in place on the clamp mount. Remove them to free the hinge bracket and re-install the bracket in the location determined in step four. Adjustment of the bolts may be required once the lid is installed back on the loader.

## Changing the Loader's Lid Hinge Location (continued)

- 6 Install the lid clamp on the loader.** Install the lid clamp in the location previously used by the lid hinge bracket. Note that the loose backing plate must be inserted and held in position behind the clamp mount to provide threads to receive the clamp bolts. Do not overtighten bolts; they may be secured once the lid is in place and the clamp position is tested for proper pull on the lid.
- 7 Re-install lid onto loader.** Line up hinge and hinge bracket. Reinstall hinge pin and connect motor and solenoid wires. Assure that the lid hinges up effectively and closes securely while making adjustments to the hinge bracket's mounting onto the clamp bracket. Assure the locking pin engages properly when opened. Check and adjust the stroke of the each lid clamp. Adjustment is possible by loosening the mounting screws and moving the clamp up or down accordingly. Once adjusted, tighten all fasteners securely.

## Connecting a Remote Demand Sensor option

A remote demand sensor option allows the user to remote the “demand” signal position of a loader to an alternate location VS using the integrated demand sensor (reed switch) that is triggered by the loader's discharge flapper valve. This is use full on drying hoppers working to less than full capacity or blender bins that do not need to be filled up completely. If this option is added by the user, the kit that accompanies the sensor will include detailed installation instructions that should be followed and will consist of:

1. Rewiring the existing demand reed switch to work with the optional remote demand sensor circuit.
2. Installation of a toggle switch on the terminal box to allow easy selection of either the integrated demand switch or the newly installed remote demand sensor.
3. Mounting and plugging in the remote demand sensor.

(For more details on Connecting a Remote Demand Sensor option, *see the separate Instructions that are provided as well as the Appendix.*)

## Connecting a Remote on/off switch option

The use of a remote on/off switch option for a loader allows the user to interrupt the operation of the loader with the flip of a switch to pause the loading function or prevent the loader from operating during maintenance, etc. When this option is added by the user, the on/off switch kit includes instructions for wiring and installation and consists of:

1. Mounting the remote on/off switch box in a convenient, yet safe location and routing the included cable to the loader terminal box.
2. Rewiring the demand input circuit to include the new switch so that a demand signal is not delivered to the the loading control unless the remote on/off switch is in the “on” position and the demand sensor or reed switch are indicating the need to the start loading.

(For more details on Connecting a Remote Demand on/off switch option, *see the separate Instructions that are provided as well as the Appendix.*)

## Installing a Fill Sensor option

A fill sensor can add valuable functions to a loader’s operation by immediately terminating a load cycle once the loader is full, saving energy and preventing overfilling. In addition, the loader control will provide an alarm signal if the loader hopper is NOT filled to the sensor, providing a usefull early warning to material loading issues.

The fill sensor is installed by drilling a hole in the loader side wall, adjacent to the material inlet. The size and specific location of this hole is detailed in instructions that accompany the fill sensor. The sensor is then secured on both sides by plastic nuts that hold the sensor in place and an “O” ring is included to maintain a vacuum seal around the sensor’s body.

The sensor is wired into the terminal box using an included cord grip, through one of the existing (plugged) holes in the top of the terminal box. Inside the term box, the sensor is connected to terminals labeled #7 (Fill Sensor) and #10 (Sensor Common). Be sure to enable the fill sensor function within the loading control, according to its detailed instructions, (*provided separately*).

The fill sensor must then be adjusted to properly sense the material being loaded by the procedure outlined in *section 5, “Sensor Adjustments”*.

## Adding a Pneumatic Solenoid to the Terminal Box

Gang-style pneumatic solenoids are housed in a protective terminal box on the back of the Access loader and are supplied, plumbed and wired as originally ordered. In the event that an additional solenoid needs to be added, the solenoid may be added as follows:

- 1 Disconnect air and electric to the loader.** It is recommended that the loader be moved to a well lit work area for this conversion.
- 2 Remove the two screws from each side of the terminal box** and open the box by tilting the top edge down and exposing the inside where the terminal block may be seen.
- 3 Assure that the new solenoid matches the voltage of the loader.** Voltages are marked on the coil section of the solenoid and must match voltage and type (AC or DC) of the loader exactly.
- 4 For loader's that have no existing solenoids in the terminal box (single material loaders),** the solenoid must be supplied with end blocks that provide mounting fixtures for the solenoid, a connecting length of tubing to link the solenoid with the incoming air line at the blowback solenoid (located on the loader lid) and a "T" that will allow the air to be split off of the incoming air supply line. All associated air fittings must also be provided.
- 5 If equipped with an existing solenoid in the terminal box,** it must first be released by removing its mounting screws from outside the terminal box and then unscrewing the blank plate on the side opposite the compressed air supply inlet.
- 6 Fasten the new solenoid directly to the existing solenoid with the supplied hardware,** assuring that all fasteners are tightened to eliminate potential leaks. The new solenoid will be installed in the same orientation as the existing solenoid. Reconnect the blank end plate to the new solenoid.

## Adding a Pneumatic Solenoid to the Terminal Box (continued)

- 7** The ganged solenoids may now be re-installed in the terminal box using the same mounting screws. Hole plugs will need to be removed from the next set of screw holes to allow the screws to be inserted. The original solenoid should end up in the same location, with the new solenoid added to the terminal block side of it. Remove the larger hole plug from the top of the terminal box to expose the red manual operator button on top of the solenoid coil.
- 8** **Wiring of the solenoid will include an understanding of the function of the new solenoid.** The wires can be stripped and inserted into the terminal strip according to the included terminal strip list. One wire will be terminated into a “neutral” terminal and the other into the appropriate function terminal, IE: “ratio”.
- 9** **The hosing of the solenoid will be dependent upon its function** and includes two hoses, connected to the appropriate pneumatic cylinder, routed through the square hole in the top of the terminal box. The hose stemming from the fitting marked “2” will supply air when the solenoid is energized. Fitting “1” supplies air when the solenoid is de-energized.



---

# Operation

Control Overview . . . . . 4-2

Accessing Control Functions . . . . . 4-2

Control Security . . . . . 4-3

Status Messages . . . . . 4-4

Alarm Messages . . . . . 4-5

Programming Messages . . . . . 4-7

Special Programming Functions . . . . . 4-10

Changing Operational Functions . . . . . 4-11

Loader Operation . . . . . 4-13

Operating Modes . . . . . 4-14

Types of Feed Tubes . . . . . 4-17

Sensor Adjustments . . . . . 4-18

## Control Overview

The MLC6 is a digital read-out control that combines reliability, ease of use and full featured operation. Its text window is back-lit to provide easy visibility and when illuminated, indicates that the control is “on”. The text window provides the ability to program the loader's operations and actively displays control functions as they occur. Alarm conditions are also displayed if and when they occur, accompanied by the front panel's red alarm light.

A combination on/off/reset switch and circuit breaker is located on the right side of the control.

## Accessing Control functions

A wide variety of control functions are built into the MLC6 control and these functions may be employed as needed through the manipulation of the three buttons on the control's front face. The square button, is the “function” button and allows the user to "page" through all of the available functions of the control, one at a time. Functions will be displayed on the text window as they are selected. The function button will scroll through all of the available functions and then repeat them as suggested by the symbol on the button. Note that many functions are 'hidden' from view, until the appropriate “security level” is accessed.

The up and down arrows allow programmed settings to be increased or decreased. In addition, combinations of these three buttons are used to access different modes of the control's operation.



## Control Security

Four “Security Levels” (A, B, C and D) are built into the control that permit both easy viewing of common operating parameters, but also prevent unintentional changes being made to lesser-used or more critical loader functions. Security levels “B” and “C” are accessed by pressing the “function” and “up” button simultaneously, whenever the control is turned on. While in each security level, changes may be freely made as needed, modes changed, etc. If no changes are made within 10 seconds, the control will default back to Security Level “A”, providing only a display of virgin and regrind times, with no ability to make changes.

The following chart shows what parameters and capabilities are available at each Security Level and what steps are required to switch between these levels:

<b>Security Level “A”</b>	For viewing (only) of virgin and regrind vacuum-on time settings (no changes can be made).	May be seen by pressing the function button from the status display screen.	This may be the only function required by processing floor personnel to confirm loader settings (only)
<b>Security Level “B”</b>	Displays and allows changes to be made to virgin and regrind time settings.	May be accessed from the Status display or Level A by pressing the function and up arrow buttons at the same time.	
<b>Security Level “C”</b>	Displays and allows changes to be made to the virgin, regrind, unload (vacuum off) and purge times, the number of blowback pulses, regrind layers, and alarm settings.	May be accessed from Level B by pressing the function and up arrow buttons at the same time.	If attempting access from Level A, Level B must be accessed first.
<b>Security Level “D”</b>	Provides the ability to change the operating characteristics of the control and use (or not) of a fill sensor.	May be accessed by pressing the function and down arrow buttons at the same time and holding them both for 5 seconds.	<b>CAUTION:</b> Security Level D makes radical changes in the way the control operates and should not be entered without a full understanding of operating parameters.

A complete set of operating parameters accompanies each mode of operation. The MLC6 control is programmed to allow the user to make only logical programming choices in each mode of operation and is designed to accommodate standard loader functions. The MLC6 may be depended upon to perform logically, unless applied in a manner inappropriate to its design.

## STATUS MESSAGES

These messages will automatically appear as functions take place in normal operation.

### READY: NO DEMAND

This status message indicates that the control is turned on, but there is no need for loading (no demand) at the loaders demand level switch (reed switch, demand sensor below the loader or rotating level switch)

### LOADING MATERIAL

This status message indicates that the loader's vacuum motor is operating and the loader should be moving both virgin and regrind materials into the loader, via a ration valve.

### LOADING VIR + REG

This status message indicates that the loader's vacuum motor is operating and the loader should be moving both virgin and regrind materials into the loader, via a ratio valve.

### VAC OFF: DUMPING

This status message indicates that the loader's virgin and/or regrind vacuum on-time has expired, the vacuum motor has stopped and the loader should now be dumping material. On Positive Discharge loaders, the valve on the bottom of the loader should be open while this message appears. This message appears only when no blowback pulses are set on the control.

### DUMP + BLOWBACK

This status message indicates that the loader's virgin and/or regrind vacuum on-time has expired, the vacuum motor has stopped and the loader should now be dumping material and the blowback function should be taking place to clean the loader filter with compressed air. On Positive Discharge loaders, the valve on the bottom of the loader should be open while this message appears. This message appears only when any number of blowback pulses are set on the control.

### LINE PURGING

This status message indicates that the virgin and/or regrind load times have expired, but the vacuum motor continues to operate while the material purge valve is closed to material flow and open to air flow to clean out the material conveying line.

# ALARM MESSAGES

These messages will appear automatically as the alarm conditions that cause them occur. An output signal is created (120 VAC) as these messages occur and the alarm light LED on the control face is illuminated.

**NO MATERIAL** alternating with

**FILL SENS UNSAT**

This alarm message indicates that the virgin and/or regrind load times have expired, but the fill sensor in the body of the loader has not been satisfied. This message will occur with every loading cycle until the load time is increased (to allow material to reach the fill sensor) or the sensor has been adjusted to properly “see” the material being loaded, *see Section 4, “Adjusting Sensors”*.

**NO MATERIAL** alternating with

**ADJ FILL SENSOR** alternating with

**RESET CONTROL**

This alarm message indicates that the fill sensor in the body of the loader continues to “see” material after a load and a dump cycle have taken place. This is usually an indication that the fill sensor is out of adjustment (too sensitive) and needs to be adjusted to a less sensitive setting, *see Section 4, “Adjusting Sensors”*. Note that this alarm message halts loader operation until the sensor is adjusted and the control reset by turning it off for three (3) seconds, then back on.

**NO MATERIAL** alternating with

**NO MATERIAL**

This alarm message indicates that the loader has made a number of attempts to load material but has not yet successfully satisfied the demand sensor below the loader. The number of loading attempts may be set by the user and this alarm message only appears after the loader has successfully loaded enough times to satisfy the demand sensor at least once after energizing the control. This function is disabled completely, if the alarm # is set to zero.

## ALARM MESSAGES (continued)

NO MATERIAL

alternating with

99 ATTEMPTS

alternating with

RESET CONTROL

This alarm message indicates that the fill sensor in the body of the loader continues to “see” material after a load and a dump cycle have taken place. This is usually an indication that the fill sensor is out of adjustment (too sensitive) and needs to be adjusted to a less sensitive setting, *see Section 4, “Adjusting Sensors”*. Note that this alarm message halts loader operation until the sensor is adjusted and the control reset by turning it off for three (3) seconds, then back on.

NO LOAD TIME SET

This alarm message indicates that the loader has made a number of attempts to load material but has not yet successfully satisfied the demand sensor below the loader. The number of loading attempts may be set by the user, *see Program Messages, SET ALARM #* and this alarm message only appears after the loader has successfully loaded enough times to satisfy the demand sensor at least once after energizing the control. This function is disabled completely, if the alarm # is set to zero.

# PROGRAMMING MESSAGES

These messages will only appear as the control is stepped through programming Security Levels A, B, C or D, as explained below. Each heading is accompanied by its factory-set value.

**Security Level A Messages** (obtained by pressing the function button once)

VIR SECS → 30

This message tells the user how many seconds of virgin load time are programmed into the control. No changes are possible at this level, only viewing of the setting. Thirty (30) seconds is the factory set default.

REG SECS → 0

This message tells the user how many seconds of regrind load time are programmed into the control. No changes are possible at this level, only viewing of the setting. Zero (0) seconds is the factory set default.

**Security Level B Messages** (obtained by pressing the function button and the “up” arrow button at the same time),

SET VIR SECS → 30

This message allows the user to program how many seconds of virgin load time are needed to fill the loader hopper. Thirty (30) seconds is the factory-set default, but this setting may be adjusted higher or lower with the up and down arrow buttons. Full range is 0 to 120 seconds.

SET REG SECS → 0

This message allows the user to program how many seconds of regrind load time are needed to supply regrind material. Zero (0) seconds is the factory-set default, but this setting may be adjusted higher or lower with the up and down arrow buttons. Full range is 0 to 120 seconds.

## PROGRAMMING MESSAGES (continued)

**Security Level C Messages** (obtained by pressing the function button and the “up” arrow button at the same time, and then again pressing the function button and the “up” arrow button at the same time)

### SET BB PULSES → 3

This message allows the user to set the number of blowback pulses that will occur after the vacuum loading function has taken place. Factory default is 3 and the up and down arrows allow the setting to be increased or decreased. Full range is 0 to 7 pulses. Note that increasing the number of pulses may slightly decrease the throughput capabilities of the loader by dedicating more time to filter cleaning.

### SET PURG SECS → 0

This message allows the user to set the purge time in seconds. This value should be changed only if a purge valve is installed on the material line. Factory-set default is 0 and the up and down arrow allow the setting to be increased and decreased accordingly. Full range is 0 to 120 seconds.

### SET ALARM # → 3

This message allows the user to set the number of times the loader will attempt to load unsuccessfully (load without satisfying the demand sensor) before an alarm occurs. Factory-set default is 3 and the up and down arrows allow the setting to be increased and decreased accordingly. Full range is 0 to 99 attempts. Note that this alarm can only occur after the loader has successfully satisfied the demand sensor at least once after energizing the control. This feature keeps the control from creating nuisance alarms while attempting to fill large hoppers or bins for the first time. Once satisfied for the first time, the control will “count” load attempts and alarm if not satisfied within the alarm attempts entered. Note that setting this parameter to “0” disables all demand sensor alarms.

## PROGRAMMING MESSAGES (continued)

### SET OFF SECS → 8

This message allows the user to set the length of time that the loader will not operate between loading cycles or the “vacuum off-time”. This setting is useful for assuring that the loaded material has enough time to gravity dump from the loader through the discharge valve. An output signal is provided as this function is energized. On Positive Discharge loaders, this setting determines how long the discharge valve is opened at the end of a loading cycle. Factory-set default is eight (8) seconds and the up and down arrow allow the setting to be increased and decreased accordingly. Full range is 4 to 999 seconds. The upper end of these settings may be used to operate a loader only periodically instead of on-demand. A popular application is for a loader that is used to keep a granulator empty by offloading the regrind into a bin. The off-seconds may be set very high so that the loader only operates every 10 minutes (600 seconds) instead of constantly.

### SET LAYERS # → D

This message allows the user to set the number of layers desired when loading both virgin and regrind materials. This function only occurs when there are seconds entered into both virgin and regrind functions. This setting then determines how many times during a single loading sequence that the ratio valve will switch between virgin and regrind to encourage layering of the materials in the loader, so the material will mix when dumped into the receiving hopper below the loader. The flow characteristics of the virgin versus regrind, the differences in material line lengths, and the differences in load times must all be considered before deciding on the proper number of layers for each loading application. To make these choices easier, a factory-set default setting (“D”), based on the amount of regrind time that has been entered, is included in the possible setting range. Its use is encouraged to prevent confusion, at least until a specific need for alternate layers settings is defined for your application. In addition to D, a 1 to 5 setting range is provided, and any of these settings will over-ride the default.

 **NOTE:** For unloading applications (where the loader is used to off load a device, like a granulator, instead of “loading” a device, like a machine hopper) the “SET ALARM #” should be set to zero. This will defeat alarm conditions that can be created because the loader may never be ‘satisfied’ by filling the vessel it is installed above.

# SPECIAL PROGRAMMING FUNCTIONS

## **Returning To Factory Defaults:**

In the event of confusion with your DustBeater control, as the result of unauthorized programming, the addition or removal of optional features, etc., it may be desirable to return your control to its original factory default settings. These settings are listed in the section titled “Programming Messages” and are shown adjacent to each category described.

To return the control to factory default settings, use the on/off switch to turn off the control, wait three (3) seconds and while holding the “up” arrow button, turn the control back on. All factory default settings will be in place as listed in the “Programming Messages” section of this manual and further changes (ie: the use of a fill sensor, ratio times, etc) may be re-entered as needed.



**NOTE:** DustBeater controls are commonly re-programmed by Conair to accommodate factory supplied options and special functions at the time of order. Returning to factory-default settings will ignore these changes and return the control to its most basic operational mode, as shown in “Programming Messages”.



# CHANGING OPERATIONAL FUNCTIONS

## Security Level “D”:

### SET LOAD + HOLD OFF

This special function is selectable to allow specially-equipped, positive discharge loaders to be used in applications where material is held within the loader after it is loaded until needed by the process, below the loader. In this application, the demand input (a closure of the demand input terminals) is sent to the control by outboard equipment and is the signal the loader looks for to dump the material from the loader. The loader automatically re-loads material after dumping, without the need for a traditional demand signal from below the loader. This function is useful for loss-in-weight blending systems, where the loader must provide an instant load of material to weight-sensitive supply hoppers below the loader, specifically when needed by the blender. The function may be turned on or off but is factory-set to off. Users should never turn this function on unless the loader and control are specifically outfitted or modified for this function.

When Load and Hold function is employed, the following jumper changes need to be made inside the control,

1. A jumper needs to be installed on the top, #1, jumper position (Demand A).
2. The bottom jumper, #5, needs to be removed.

### NO FILL SENSOR

This feature changes the control’s operation to terminate loading with the use of a fill sensor, installed in the loader body. It also provides alarm functions, minimizes load time and other benefits. To be employed, a proper sensor must be installed in the loader body and connected to the terminal box, the proper jumper arrangement needs to be made inside the control and the feature needs to be turned on. It is usually factory-set to NO FILL SENSOR (unless a fill sensor was originally installed) but may be easily changed to FILL SENSOR USED, using the up or down arrows. Typically, the jumper settings inside the control are already made to accept the common sensors used by Conair for this function, so the only change necessary is to turn this function on to the FILL SENSOR USED display on the control. If the installed sensor does not work properly and is suspected to be a model not specifically selected by Conair for use with this loader and control, then the jumpers inside the control may also need to be changed.



**CAUTION:** These functions should be manipulated with caution since they can alter the entire operation of the control. Some functions must be entered in coordination with jumper settings inside the control, as described below. All special functions are entered by accessing Security Level D, obtained by pressing the function button and the “down” arrow button at the same time and holding for 5 seconds.

## **CHANGING OPERATIONAL FUNCTIONS** (continued)

### **MOTOR LOADER**

This feature changes the control to operate in a self-contained (motor loader) mode or in a central vacuum, series wired loader mode (Selectronic 6). Users should never change this setting. It is factory-set to MOTOR LOADER and should be left unmodified.

### **HIGH CONTRAST**

This selection allows the control's text window to be optimally viewed in high contrast from a straight-on viewing angle versus a lower, low contrast viewing angle. It is factory set to HIGH CONTRAST.

## Loader Operation

Loading is accomplished by inserting the feed tube(s) into the material supply, turning on the control, allowing material to flow into the loader and adjusting the virgin (and/or regrind) load time as described below. The flow of material may be optimized by adjusting the feed tube's "air to material" settings covered in *Section 4, "Feed Tube Settings"*.

Start of the loading function is triggered by the demand switch, integrated into the gravity discharge valve on the bottom of the loader (or provided as a separate switch). On a "hopper loader", when the flapper on the loader is closed by its own counterweight, it is an indication that the loader is free of material and must provide more material by loading. The standard demand switch is a "reed" type that magnetically interacts with a small magnet, located on the flapper. As the flapper closes and the magnet gets close to the reed switch, the switch closes, providing a demand signal to the loader control. From that point, the loader control's timed functions take over, providing a complete load cycle with the vacuum motor, filter cleaning blowback function, etc. resulting in material dumping from the loader into the receiving vessel below.

After discharging material into the receiving vessel below the loader, the cycle may repeat or the discharge flapper may be held open with the material that was discharged from the loader. If the flapper closes, the cycle will repeat. If the flapper is held open by the material, it is an indication that there is no need for another load cycle and the loader will wait until the material level falls, the flapper closes, the magnet comes close to the reed switch and triggers another load cycle.

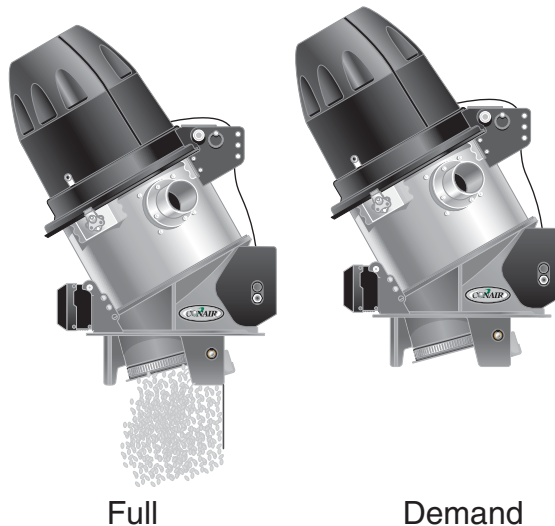

# Operating Modes

The Access self-contained loader is capable of operating in several different modes, based upon the options that were supplied. The following instructions explain these modes, starting with the most common versions.

## Single Material, Hopper Loading Operation

**1 Set Virgin Seconds on Control; no fill sensor:** Virgin seconds may be input at Security Level B by simply using the up or down arrow buttons to adjust vacuum-on time accordingly. The loader comes equipped with a factory preset of 30 seconds. Load time should be set with enough seconds to 'just fill' the vacuum loader. 'Just full' is indicated by an audible rise in pitch of the vacuum motor and/or material no longer flowing in the material conveying line.

 **Note:** Too much loading time will prematurely wear out the vacuum motor, pack material in the conveying line, prematurely blind the filter and possibly cause material shortages by wasting valuable vacuum time by attempting to fill a loader that is already full. Too few seconds set on the control may starve your process with numerous on and off cycles that yield too little material transfer. Often times, virgin load time is best adjusted by trial and error, to provide sufficient vacuum-on time to “just fill” the loader before the motor shuts off.

### **2 Set Virgin Seconds with optional Fill Sensor:**

If your Access Loader is equipped with a “fill sensor” (a capacitance sensor, mounted in the loader body), the load time should be set slightly higher than typical load time, since the fill sensor will terminate vacuum loading once it 'sees' material in the loader, during loading. In this way, a correctly adjusted fill sensor will optimize loading cycles automatically. In addition, the loader control will provide an 'alarm' signal (plus an alarm output) if the fill sensor does not see material by the time the load time setting expires. To avoid nuisance alarms, the load time setting should be set amply more than the required number of seconds it takes to fill the loader. *See Section 4, “Alarms Messages”, for more information on alarms and alarm settings.* Note that the fill sensor must be adjusted for proper sensing of the loaded material, (*see Section 4, “Sensor Adjustments”*).

## Operating Modes (continued)

### **3 Check and adjust additional settings:**

Additional control settings are provided within the control that are factory set to common parameters but are accessible and changeable via Security Level “C”.

See the “Unload” and “Blowback” control sections for more information, but the factory settings of these parameters are usually very acceptable for most operations and do not need further adjustment.

### **Two Material, (Ratio) Loading Operation**

Follow all guidelines listed above under “Single Material Loading”. The operational parameters are exactly the same, except that the operator will now be loading two materials during the vacuum on cycle through the use of the 'ratio' function and a ratio valve mounted on the inlet of the loader.

Two control settings govern the operation of the ratio valve: The “regrind seconds” (listed as REG SECS and accessible through Security B) and “regrind layers” (listed as REG LAYERS and accessible through Security Level C). The regrind seconds setting simply adds additional load time to the operation of the loader to allow an amount of time to be dedicated to transferring regrind material. In operation, virgin seconds (VIR SECS) plus regrind seconds (REG SECS) totals the overall vacuum-on time of the loader's vacuum motor. Both of these values are viewable in Security Level A, by simply pressing the function button and these settings are changeable in Security Level B. The regrind layers setting provides an alternating of the virgin and regrind plungers of the ratio valve as material is loaded, so that materials are somewhat mixed as they enter the loader. Based on this setting, the control will use the time settings established for virgin and regrind and alternate the valve as many times as set on the regrind layers setting indicates during the course of each loading cycle. This setting is viewable and changeable in Security Level C.

## Two Material, (Ratio) Loading Operation (continued)

To make selecting the appropriate number of layers as easy and logical as possible, a “default” setting (“D”) is provided that uses the regrind seconds setting to determine a logical number of layers for the ratio valve. This feature allows the user to select either “D”, where the control will decide how many layers should be employed, or you may input a number between 1 and 5, where the virgin and regrind time settings are ignored and the ratio valve will switch the number of times selected. The use of the default “D” selection is encouraged unless special conveying parameters are required.

**IMPORTANT:** It is highly recommended that the ratio function be employed only for applications that allow the full use of all regrind as it is generated.

The ratio function of any loader, should not be relied upon for accurate proportioning of materials. The loader takes responsibility for providing the air flow required for vacuum loading, opening and closing of the ratio valve in the approximate time sequences as set on the controls. The loader is not able to interpret the differences in material bulk density, flow characteristics and conveying distances that can affect the delivery of the desired proportions of each material. In fact, the loader cannot determine if material is even flowing through each conveying line. Adjusting and compensating for these parameters are the responsibility of the user. In this case, the ratio function provides a valuable asset to users, by efficiently loading an approximate proportion of regrind along with virgin materials. Virgin time (VIR SECS) will usually need to be adjusted with the use of the regrind time (REG SECS), to compensate for the stop/start cycling of each material as the ratio valve switches and to compensate for the differences in flow characteristics between virgin and regrind. Conveying distance differences must also be taken into account. Sluggish material conveying characteristics can prohibit the use of too many layers. Observing the material flow in the flex hose will help to guide the simple adjustments to achieve your desired ratio loading performance.

## Types of Feed Tubes

Feed tubes may be provided in a variety of styles made to match the needs for your production. Whether they are horizontal types like distribution boxes (take off boxes) or horizontal bin tubes, or vertical types like wands that are made to be hand inserted into material bins, they need to be adjusted for their air-to-material ratio. Conair provides vertical feed tubes that provide a fixed amount of material entry with adjustments for air flow and horizontal types with fixed air flow and adjustments for regulating material entry.

### Vertical Feed Tube Adjustments

Smooth material flow is controlled by opening or closing the holes at the top of the feed tube, either with the flex hose connected to the feed tube or with strong tape (duct tape is commonly used).

Start by inserting the feed tube into the supply of material and observing its conveying action. If the material surges (“gulps” as it is conveyed), clear the line by lifting the feed tube out of the material supply and allowing the line to clear. Then cover holes on the feed tube and retest until the material conveys smoothly.

Covering all holes conveys the maximum amount of material with minimal air, producing the highest volume of material flow but at the slowest possible conveying speed (a low air-to-material ratio). This can make conveying over longer distances or through bends more difficult. With holes uncovered, a ‘thinner’ flow of material is achieved and the greatest conveying speeds are realized. This is a high air to material ratio and can create undesirable material fracturing in the loader, “angle hair” in the conveying lines and material dust.

Test several cycles to achieve the desired results by covering or uncovering feed tube holes. Once conveying is fine tuned, the feed tube should be twisted in its conveying hose to place the open feed tube holes up, so that material cannot fall out of the holes when conveying stops.

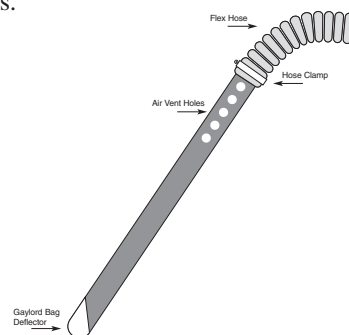

## Horizontal Feed Tube Adjustments

Start by loosening the thumb screw next to the adjustable air inlet tube and push it all the way in, closing off material flow and allowing 100% air to flow through to the loader. Over the course of several cycles, pull the air tube out slowly until optimum conveying is achieved with minimal surging (gulping). If surging does occur, clear the conveying line by pushing the air inlet tube all the way in until the line centers and trial and error settings may be attempted again.

Once optimum settings are achieved, the air inlet position may be locked into position with the thumb screw.

 **NOTE:** As described in “Types of Feed Tubes”, different types of feed tubes feed material mixed with air in different ways. Conair horizontal feed tubes (distribution boxes, etc.) provide adjustments for material flow with a fixed amount of conveying air for optimum material flow. Competitive units may not work in the same manner.

## Sensor Adjustments

Capacitive Level Sensors use their own on-board electronics to sense the presence or absence of material located in front of the flat face of their cylindrical bodies and trigger loader control functions as a result. Typical uses are as fill sensors, to indicate a full loader condition and terminate the loading cycle and demand sensors, which start loading by indicating the absence of material in a bin or sight glass. Before use, the control must be set to accept and operate with the specific sensor model being used and the sensor must be set to detect the material being conveyed and to ignore the sensor’s surroundings (metal, sight glasses, etc.) as well as set to ignore material dust that may collect on the sensor face. In some cases, sensors must be readjusted for each new material being conveyed.

### General Sensor Sensitivity Adjustments

Every sensor is equipped with a multi-turn screwdriver adjustment, located within a small hole on the corded end of the sensor body. Most are also equipped with an indicator light to signal response by the sensor. With the sensor in the correct position for operation, (See Section 4, “Demand Sensors”) the adjustment screw can be rotated clockwise for more sensitivity and counter-clockwise for less sensitivity. The small signal light on the sensor illuminates when the sensor does not “see” material. As a guide, the light will go off, when the sensor detects something in front of its face. It should be adjusted to ignore glass and adjacent surfaces and fine tuned to respond only to the presence of material. This may require several back and forth adjustments to optimize the setting.



## Demand Sensors

Demand sensors are utilized in two different ways: In direct contact with material or through sight glass.

When coming in direct contact with material, it is recommended that the sensor be initially adjusted for sensitivity and then re-adjusted, once the sensor becomes coated with typical material fines, common to plastics conveying.

Sensors that sense material through glass or plastic windows must be adjusted to “ignore” the window and sense only the material on the other side. These adjustments must be made with the material to be conveyed, so it suggests that they are made during normal operation. Furthermore, the sight glasses may become coated with a certain build-up of plastic dust (from static electricity attraction, etc.) and the sensor should be adjusted (and/or re-adjusted) to ignore this condition. Sensors that are mounted in movable brackets that allow different levels to be set must maintain the same distance setting from the sight glass to assure consistent operation, or be reset for sensitivity. Optimum distance from sight glass for a sensor is the thickness of a piece of paper. This setting permits the closest possible contact with the glass or window, yet is back just enough to be isolated from heat variations that could effect sensor operations.

## Fill Sensors

Fill sensors are installed right in the loader body and come in direct contact with material, as it is being loaded. If set correctly, the time the material contacts the sensor is brief, since loading is terminated by the sensor and unloading usually occurs immediately afterwards. If possible and practical, the loader’s unload function may be interrupted by holding the discharge valve closed, long enough to set the sensor’s sensitivity. If not possible, trial and error settings may be made during repeated loads to set the sensor to terminate the loading cycle. As with other sensor adjustments, it is recommended to check the setting after the loader has operated for a period of time, and re-adjust it if need be, to allow the sensor to ‘ignore’ material dust that may have collected on the sensor face.

## **Demand Sensors**

Demand sensors are utilized in two different ways: In direct contact with material or through sight glass.

When coming in direct contact with material, it is recommended that the sensor be initially adjusted for sensitivity and then re-adjusted, once the sensor becomes coated with typical material fines, common to plastics conveying.

Sensors that sense material through glass or plastic windows must be adjusted to “ignore” the window and sense only the material on the other side. These adjustments must be made with the material to be conveyed, so it suggests that they are made during normal operation. Furthermore, the sight glasses may become coated with a certain build-up of plastic dust (from static electricity attraction, etc.) and the sensor should be adjusted (and/or re-adjusted) to ignore this condition. Sensors that are mounted in movable brackets that allow different levels to be set must maintain the same distance setting from the sight glass to assure consistent operation, or be reset for sensitivity. Optimum distance from sight glass for a sensor is the thickness of a piece of paper. This setting permits the closest possible contact with the glass or window, yet is back just enough to be isolated from heat variations that could effect sensor operations.

## **Fill Sensors**

Fill sensors are installed right in the loader body and come in direct contact with material, as it is being loaded. If set correctly, the time the material contacts the sensor is brief, since loading is terminated by the sensor and unloading usually occurs immediately afterwards. If possible and practical, the loader’s unload function may be interrupted by holding the discharge valve closed, long enough to set the sensor’s sensitivity. If not possible, trial and error settings may be made during repeated loads to set the sensor to terminate the loading cycle. As with other sensor adjustments, it is recommended to check the setting after the loader has operated for a period of time, and re-adjust it if need be, to allow the sensor to ‘ignore’ material dust that may have collected on the sensor face.

# Maintenance

---

Filter Cleaning . . . . .	5-2
Motor Brush Checking/Replacing . . . . .	5-3
Brushless Motor Filter Cleaning/Replacement. . . . .	5-6

## Conveying Filter Cleaning

The filter on your Access Loader is designed to protect the motor from damage by plastic pellets, regrinds, and fines that are drawn to the loader by the vacuum action of the motor. The filter, situated between the vacuum hopper and the lid of the loader, separates vacuum conveying air from the loaded material and can become caked with material dust as material is loaded. The blowback function (if your Access Loader is equipped with it), which takes place at the conclusion of each loading cycle, does a good job of cleaning the filter, but occasionally the filter will need manual cleaning, or eventual replacement, to stay effective. The schedule of cleaning will depend upon how much material and how clean the material being conveyed is (dusty regrind causes rapid filter blinding).

### Removing the filter for cleaning

- 1 Disconnect power to the loader.**
- 2 Open the lid by releasing the perimeter clamps and tilting the lid position away from you on its hinge.** When it is near a vertical position, it will lock into position, for safety. Once the lid is locked into position, the filter may be removed.
- 3 Clean the filter with compressed air, blowing against the motor side (labeled “This Side Up”),** or with a vacuum cleaner sucking against the bottom, fabric side of the filter.

Be sure to discard and replace any filter that has developed a hole, or has become hopelessly clogged with material dust. Do not attempt to repair a damaged filter.

The filter in a Conair Loader performs double duty as an effective seal between the hopper body and the lid of the loader. Examine the integrity of the rubber perimeter seal to be sure that the lid will seal effectively when the filter is reinstalled into the loader.

## Reinstalling the filter after cleaning

Reinstall the filter, by placing it carefully on top of the loader body's top flange, and prepare to close the lid down around it. The filter is labeled "This Side Up," indicating the side to be installed towards the motor. The opposite side will come in contact with material as it is loaded.

While gripping the lid firmly, pull the silver safety knob to release the lid's safety lock (do NOT pull the hinge release pin, supplied with a ring). This will allow the lid to be lowered back into operating position on the body of the loader, with the filter contained between the lid and the body.

Be sure to keep from crushing the filter or filter seal with the lid, in the event the filter is reinstalled off-center. The loader lid is secured with the perimeter twist lock clamps. Reconnect compressed air hose and the power cord.

## Cleaning the Loader body

The loader body is hinged for easy access to the loader body. The inside of the loader body can be wiped clean, vacuumed, or blown with compressed air.

## Compressed Air Filter Cleaning

The compressed air connection of the loader may be connected to a moisture trap to prevent troublesome moisture, contained in the air supply, from entering the loader. The filter bowl of this moisture trap must be emptied regularly to drain the water from the air system. Inspect the bowl periodically with the compressed air supply turned off, to clean or replace the filter element if needed to remove contaminant accumulation.



**CAUTION:** Be sure to wear safety glasses to guard against air-borne material particles if compressed air cleaning is employed. Be sure that the compressed air being employed is completely dry and will not add moisture to the filter media. If moisture is added, the collected fines will probably solidify into clumps that will be very difficult to remove. If moisture is accidentally introduced, set the filter aside and allow it to thoroughly air dry before vacuuming at a later time, or replace it with a new filter.

# Motor Brush Checking/Replacement

The vacuum motors employed on Self-Contained Material Loaders are powered by brush type, high RPM motors that require maintenance to the brushes on a regular basis. The brushes should be checked to prevent complete brush wear down, which could be damaging to the motor armature and the brushes should be replaced if they are extensively worn.

Disconnect power to the loader before attempting brush maintenance.

Motor brush service can be performed on the loader or the lid of the loader may be removed to make service easier. To remove the loader lid for service:

## Loader Lid Removal:

- 1** With the loader lid closed, disconnect power to the loader and unplug the motor's power cord.
- 2** Disconnect the air supply from the blowback solenoid and disconnect the electrical connector from the solenoid coil by completely loosening the small screw in the center of the coil's connector. The screw can remain in place while the connector is pulled off the coil. You are now ready to remove the loader lid.
- 3** Loosen the two twist clamps on the perimeter of the lid that lock the lid closed. Keep the lid closed and pull the hinge pin from the hinge area of the lid. The hinge pin connects the loader lid to the loader body and provides the pivot point for the hinge action. Once released, the lid may then be carefully lifted off of the loader body. Use caution as the motor's weight may be deceiving once the lid is released from the hinge.

The vacuum motor itself is contained below the plastic shroud on the loader lid, which can be easily removed to expose the motor.

- 4** To remove the shroud, loosen (do not remove) the three bolts located around the perimeter of the motor shroud. The holes in the shroud are slotted and once the screws are loose, the shroud may then be carefully lifted off the screws to expose the motor below it. Use caution to avoid putting strain on the motor wires that pass through the shroud as the shroud is removed.

Access to the brush area differs on the two models of Access Loaders covered in this manual.

## Motor Brush Checking/ Replacement (continued)

### To access the brush on the AL5 Loaders (7/8 Hp Motor with 4 brushes):

The brushes on the AL5 are contained within two circular caps visible on each side of the uppermost section of the motor. Disconnect power and remove the acorn nuts that secure the circular caps to the motor body. Inside each cap are two spring mechanisms that secure the brushes, under tension, against the motor armature. The brushes may be removed by prying off the spring clips. Examine the brushes carefully to be sure that the brush is still intact and not disintegrated from use.

The brush should be at least 1/2 inch long to be returned to service. If any brush is not of this size, replace all four immediately.

### To access the brush on the AL2 Loaders (5/8 Hp Motor with 2 brushes):

The brushes on the AL2 will be visible on each side of the motor, held in place with two slot headed screws. The brushes and their holders may be freed by removing the screws. Examine the brushes carefully to be sure that the brush is still intact and not disintegrated from use.

The brush should be at least 1/4 inch long (as measured from the motor end of the brush holder) to be returned to service. If either brush is not of this size, discard the brushes and holders and replace both immediately.

Once brush service is complete, assure that all brush connectors and covers are replaced and tightened securely. Replace the motor shroud by carefully reinstalling it over the lid bolts that fit into the slots of the shroud, while assuring that internal wires have not become tangled or strained. Tighten the bolts to secure the shroud.

### Reinstalling The Loader Lid

If the lid was removed from the loader for service, reinstall it by placing its hinge into the hinge mechanism of the loader and reinstalling the ringed hinge pin. The lid is likely to require some care in aligning the lid and body hinge components while the hinge pin is installed. Double check that once the pin is installed, the hinge opens and closes easily and that the safety catch operates correctly as the lid is opened.

## BRUSHLESS MOTOR FILTER CLEANING/REPLACEMENT

The brushless motor operates differently than traditional brush motors, by using solid state circuitry within the motor to replace the function of brushes and allow the motor to operate at the high speeds necessary for efficient vacuum operation. This sophisticated circuitry is housed in the top section of the motor housing and is cooled by a fan that draws ambient air into the motor through the top, cools the solid state circuitry and then exhausts out the base of the motor. This air path must be kept clear and clean to allow the brushless motor to operate properly. To prevent the accumulation of dirt, dust and debris in the motor's circuitry that could foul motor operation, a small disc filter is fixed to the top of the motor that must be kept clean to allow free air movement into the top of the motor.

The filter is held in place on top of the motor by small metal tabs. First, disconnect power to the motor by unplugging its plug. Then, the filter may be easily removed without tools, by simply gripping the filter media and pulling it out from under the tabs. Once removed and away from the loader, it may be vacuumed or blown off with compressed air to restore it to a clean condition before returning it to service on top of the motor. You should be able to easily see light through a clean filter. Filters caked with dirt or debris, or filters that are ripped or incomplete should be replaced. Replacement filters (part number 105-548-02) are available through the Conair Parts or Service Department. The brushless motor should not be operated without a filter in place.

In most cases, it is recommended that before a cleaned filter is returned to service, the top of the brushless motor is also cleaned to remove collected dust and debris that may foul the motor's operation. Use a strong vacuum cleaner to clean the motor's top vents and remove any dirt that may have collected on the motor circuitry itself, below the vents. Compressed air may also be used, but in the event of extreme dirt, debris may actually be blown deeper into the motor, creating other issues. Use good judgement and observe all safety procedures for the use of compressed air especially safety glasses.

Loaders that operate in clean environments, without airborne dust or debris will not need servicing of the motor filter very often. Loaders that require this service frequently, due to dirty operating environments, should be moved if possible to prevent erratic performance from a frequently fouled filter.



## **Thermal OverLoad**

Note that a dirty filter can allow the motor to overheat and trip a thermal overload within the motor, halting its operation. This thermal overload can only be reset to continue operation (after thoroughly cleaning the filter and motor circuitry) by allowing the motor to cool for 5 minutes, then unplugging the motor power cable for 30 seconds. All power to the motor must be interrupted in this manner to reset the thermal overload inside the motor. Simply turning the loader control off will not reset the motor's internal overload.

Once the motor overload is reset by disconnecting and reconnecting power, the filter and motor are cleaned and the filter is re-installed on top of the motor, the motor should restart as a part of normal loader operation. If it does not, more severe motor damage or other problems may have occurred. Check the troubleshooting section of this manual or call Conair service for more information.



# Troubleshooting

---

Before beginning . . . . .	6-2
A few words of caution . . . . .	6-3
Conveying Problems . . . . .	6-4

## BEFORE BEGINNING

You can avoid most problems by following the recommended installation and maintenance procedures outlined in this User Guide. If you do have a problem, this section will help you determine what caused it and how to fix it.

### Before you begin troubleshooting:

**Find the wiring diagrams that were shipped with your equipment.** These diagrams are the best reference for correcting a problem. The diagrams also will note any custom features, such as special wiring or control options, not covered in this User Guide.

**Verify that you have manuals for other equipment in the process line.** Solving problems may require troubleshooting malfunctions or incorrect operating procedures on other pieces of equipment.

### A FEW WORDS OF CAUTION



**WARNING:** This machines should be adjusted and serviced only by qualified technical personnel who are familiar with construction and operation of this type of equipment.



**WARNING: Voltage hazard.**

Troubleshooting the electrical system of this equipment requires use of precision electronic measuring equipment, and may require access to the electrical enclosure while power is on. Exposure to potentially harmful voltage levels may be unavoidable. These troubleshooting procedures should be performed only by qualified electrical technicians who know how to use this precision electronic equipment and who understand the hazards involved.



**WARNING: Disconnect power and compressed air before servicing.**

Always disconnect and lock out power and compressed air supplies to this equipment before performing maintenance or repair. Failure to do so could result in personal injury caused by the unexpected energization of this equipment.

# Conveying Problems



**WARNING: Disconnect power and air sources.** Always disconnect the loader from its main power source and compressed air source before servicing. This prevents the loader from starting during servicing, which could cause personal injury.

## Problem

Low or no material flow.

## Possible cause

Does the filter need to be cleaned?

Is there an overload on the circuit breaker(s)?

Are there kinks in the flex hose?

Are there holes or cracks in any of the material lines?

Are hose connections too loose?

Are material to air adjustments at the material pickup device correct?

Do you have enough material at the source?

Are the motor brushes worn?

## Solution

Check the filter and clean if it is clogged with dust or fines. Clean the filter. *See Section 5, "Cleaning the Filter".*

Reset the circuit breaker if it is tripped. Check for cause.

Check the material flex hose line for loops and "S" curves. Remove any loops and "S" curves in the flex hose. Try to keep the hose as straight as possible.

Check the material lines for holes, cracks or other signs or excessive wear. Replace worn flex hose.

Check vacuum and material line hose connections for leaks. Hose clamps should be secured near the end of the hose connection.

Check the material to air adjustments at the feed tube or distribution box to make sure they are properly adjusted. *See Section 4, "Adjusting Feed Tubes".*

Replace/refill the material container or reposition the feed tube.

Check the motor brushes. If any brush is too short, replace all brushes. *See Section 5, "Motor Brush Checking/Replacing".*

## Conveying Problems



**WARNING: Disconnect power and air sources.** Always disconnect the loader from its main power source and compressed air course before servicing. This prevents the loader from starting during servicing, which could cause personal injury.

Problem	Possible cause	Solution
Low or no material flow (continued).	Has material plugged the tubing or flexible hose?	Remove the conveying line from the material and check vacuum. If necessary, uncouple the lines, remove blockages and reassemble the line. Readjust for proper material flow. (See Section 5, "Adjusting feed tubes")
Brushless Motor does not respond in any way.	Thermal overload inside motor has tripped due to overheating.	Clean brushless motor filter, vacuum clean top of motor, reset thermal overload by unplugging motor. (See Section 5, "Brushless Motor Filter Cleaning/Replacing")
Motor speed sounds like it varies as it operates (brushless motor option only).	120 volt input power is below standard. Motor is attempting to automatically compensate.	Correct power supply or switch power receptacle that loader is connect to.
Motor speed sounds like it varies as it operates.	Motor brushes are used up. Increased arcing is creating uneven motor speeds.	Check and/or replace brushes See Section 3, "Installing the Hopper Loading Version".
	Are sensor (s) adjusted properly?	Make sure the demand sensor is set a proper distance from the glass, and is positioned at the level of material you want to maintain.

# Conveying Problems



**WARNING: Disconnect power and air sources.** Always disconnect the loader from its main power source and compressed air course before servicing. This prevents the loader from starting during servicing, which could cause personal injury.

Problem	Possible cause	Solution
Motor speed sounds like it varies as it operates (continued).	Is there a vacuum air leak?	<p>Check o-rings and gaskets for damage or leaks.</p> <p>Check the (optional) volume fell sensor, for a tight seal.</p> <p>If a blowback option is installed, make sure the compressed air line is connected at the lid.</p> <p><b>For Direct Feed Models</b> Check the mounting gasket and plate for a tight seal. If the mounting is not sealed 100%, you may need an isolator valve to maintain vacuum.</p>
Loader will not cycle.	Are all electrical connections correct?	<p>Check to make sure the loader control is plugged into a power source.</p> <p>Check all electrical connections.</p> <p>Check to make sure the sensor(s) is connect properly.</p>
Loader does not respond. Sensors do not respond.	Shorted output device. Wrong voltage applied to unit. Internal Fuse #F1 is open.	Replace fuse #F1.

## Conveying Problems



**WARNING: Disconnect power and air sources.** Always disconnect the loader from its main power source and compressed air course before servicing. This prevents the loader from starting during servicing, which could cause personal injury.

Problem	Possible cause	Solution
No back light on control face.	If unit was opened for any reason, possible misalignment of internal connectors opened internal Fuse #F2.	Examine connections inside. Correct connections. Replace fuse #F2.
Sensors do not respond, but control illuminates.	Sensor(s) incorrectly wired. Internal Fuse #F3 opened.	Correct sensor wiring. Replace fuse #F3.

**Fuse descriptions:**  
F1=3.15Amp, 8mm Round, inside control  
F2 and F3=0.5 Amp, 8mm Round, inside control





**Additional manuals and prints for your Conair equipment may be ordered through the Customer Service or Parts Department for a nominal fee.**

## We're Here to Help

Conair has made the largest investment in customer support in the plastics industry. Our service experts are available to help with any problem you might have installing and operating your equipment. Your Conair sales representative also can help analyze the nature of your problem, assuring that it did not result from misapplication or improper use.

## How to Contact Customer Service

To contact Customer Service personnel, call:



From outside the United States, call: 814-437-6861

You can commission Conair service personnel to provide on-site service by contacting the Customer Service Department. Standard rates include an on-site hourly rate, with a one-day minimum plus expenses.

## Before You Call...

**If you do have a problem, please complete the following checklist before calling Conair:**

- Make sure you have all model, control type from the serial tag, and parts list numbers for your particular equipment. Service personnel will need this information to assist you.
- Make sure power is supplied to the equipment.
- Make sure that all connectors and wires within and between control systems and related components have been installed correctly.
- Check the troubleshooting guide of this manual for a solution.
- Thoroughly examine the instruction manual(s) for associated equipment, especially controls. Each manual may have its own troubleshooting guide to help you.
- Check that the equipment has been operated as described in this manual.
- Check accompanying schematic drawings for information on special considerations.

## Equipment Guarantee

Conair guarantees the machinery and equipment on this order, for a period as defined in the quotation from date of shipment, against defects in material and workmanship under the normal use and service for which it was recommended (except for parts that are typically replaced after normal usage, such as filters, liner plates, etc.). Conair's guarantee is limited to replacing, at our option, the part or parts determined by us to be defective after examination. The customer assumes the cost of transportation of the part or parts to and from the factory.

## Performance Warranty

Conair warrants that this equipment will perform at or above the ratings stated in specific quotations covering the equipment or as detailed in engineering specifications, provided the equipment is applied, installed, operated and maintained in the recommended manner as outlined in our quotation or specifications.

Should performance not meet warranted levels, Conair at its discretion will exercise one of the following options:

- Inspect the equipment and perform alterations or adjustments to satisfy performance claims. (Charges for such inspections and corrections will be waived unless failure to meet warranty is due to misapplication, improper installation, poor maintenance practices or improper operation.)
- Replace the original equipment with other Conair equipment that will meet original performance claims at no extra cost to the customer.
- Refund the invoiced cost to the customer. Credit is subject to prior notice by the customer at which time a Return Goods Authorization Number (RGA) will be issued by Conair's Service Department. Returned equipment must be well crated and in proper operating condition, including all parts. Returns must be prepaid.

Purchaser must notify Conair in writing of any claim and provide a customer receipt and other evidence that a claim is being made.

## Warranty Limitations

**Except for the Equipment Guarantee and Performance Warranty stated above, Conair disclaims all other warranties with respect to the equipment, express or implied, arising by operation of law, course of dealing, usage of trade or otherwise, including but not limited to the implied warranties of merchantability and fitness for a particular purpose.**

# Remote Demand Sensor Kit with Demand Selector Switch

written instructions on reverse side

## Vacuum Receiver Terminal Block

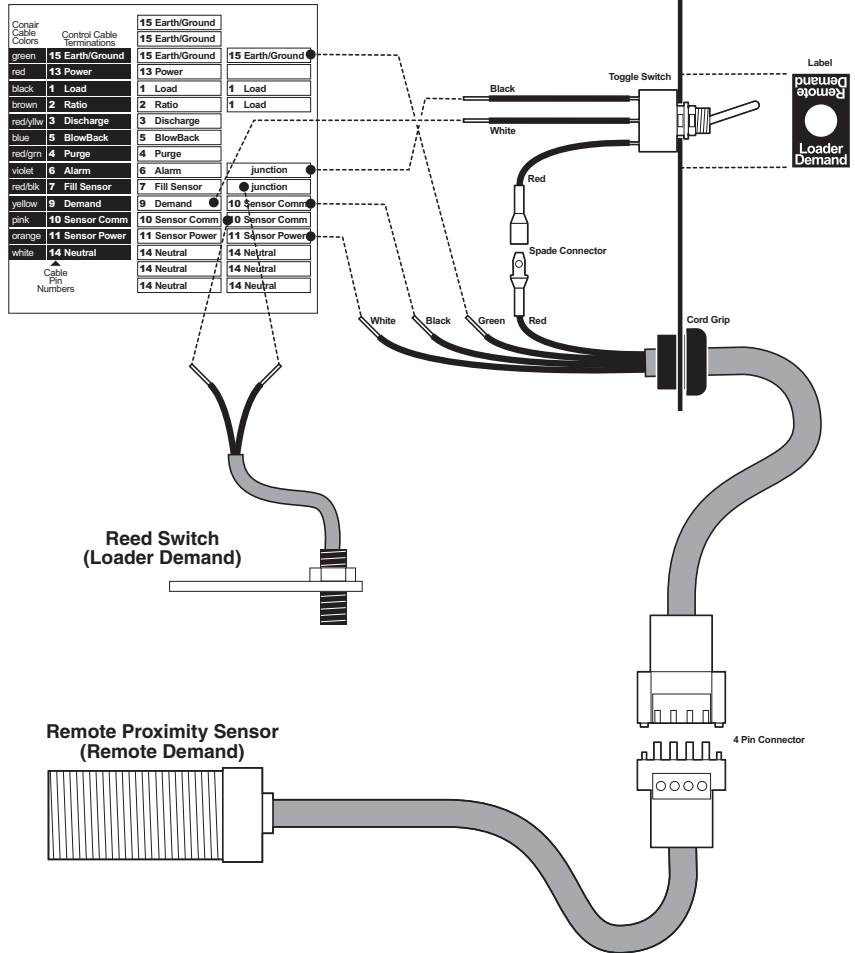

## Remote Demand Sensor Kit with Demand Selector Switch

diagram on reverse side

### Wiring Instructions

Note: All wiring must be performed by a qualified electrician with strict adherence to local electrical codes:

Prepare terminal box for installation of switch label, switch, and 4 pin receptacle pigtail cable. The switch will be installed in the small hole of the terminal box's top surface. The 4 conductor cable can be located in any of the remaining holes. Remove appropriate hole plugs and clean surface.

1. Peel backing from label and install label over small switch hole. Align long edge of label with adjacent edge of terminal box enclosure.
2. Install switch in the hole so that the terminal with the spade connector is located on the "Loader Demand" side of the label. Use accompanying hardware to firmly secure switch to the terminal box.
3. Install pigtail of 4 pin receptacle cable through the selected hole in the terminal box using the accompanying cord grip. Make sure that there is enough wire length inside the box to connect to the terminal block and switch.
4. Connect the spade terminal from the toggle switch to the spade terminal of the 4 pin receptacle cable.
5. Locate the loader/receiver's reed switch connections on the terminal block. It should be connected to #9 (Demand) and #10 (Sensor Comm). Press the adjacent terminal block lever and remove the reed switch wire from the #9 terminal. Relocate this reed switch wire to either of the "junction" terminals by pressing the adjacent lever of this terminal and inserting the wire. Check to see that it is firmly installed by tugging on it lightly.
6. Insert the wire from the center terminal of the toggle switch into the now vacant #9 (Demand) terminal.
7. Install the remaining wire of the switch into the open "junction" terminal on the terminal block.
8. Connect the 3 remaining wires from the 4 pin receptacle cable as follows:  
Connect the Green wire to a #15 (Earth/Ground) terminal.  
Connect the Black wire to a #10 (Sensor Comm) terminal.  
Connect the White wire to an #11 (Sensor Power) terminal.

Wiring is now complete and providing all wires are firmly connected, the terminal box may now be closed.

Connect the remote demand sensor's plug to the receptacle and route the wire away from hot surfaces and moving parts to the desired sensor location. If the cable will not reach, an extension cable may be ordered from Conair parts or service. Once the sensor is installed and in operation with material, it will need to be adjusted for sensitivity according to instructions included with your loader/receiver.

### Using the Remote Demand Sensor

Place the toggle switch in the "Loader Demand" position. Energize the loader/receiver and observe operation. The loader, providing there is no material or other obstruction holding the discharge flapper open, should load repeatedly as expected.

Place the toggle in the "Remote Demand" position. The loader/receiver will now respond to the need for material as determined by the remote demand sensor. In order to work reliably and indicate the presence or absence of material, the sensor is likely to need calibration. Follow the procedure outlined in your Access Loader or Access Receiver instruction manual for sensor calibration.



## Remote On/Off Switch Module

written instructions on reverse side

### Loader/Receiver Terminal Block

Conair Cable Colors	Control Cable Terminations	
green	15 Earth/Ground	15 Earth/Ground
red	13 Power	13 Power
black	1 Load	1 Load
brown	2 Ratio	2 Ratio
red/yelw	3 Discharge	3 Discharge
blue	5 BlowBack	5 BlowBack
red/grn	4 Purge	4 Purge
violet	6 Alarm	6 Alarm
red/bk	7 Fill Sensor	7 Fill Sensor
yellow	9 Demand	9 Demand
pink	10 Sensor Comm	10 Sensor Comm
orange	11 Sensor Power	11 Sensor Power
white	14 Neutral	14 Neutral
		14 Neutral
		14 Neutral
		14 Neutral

\* Depends on control type

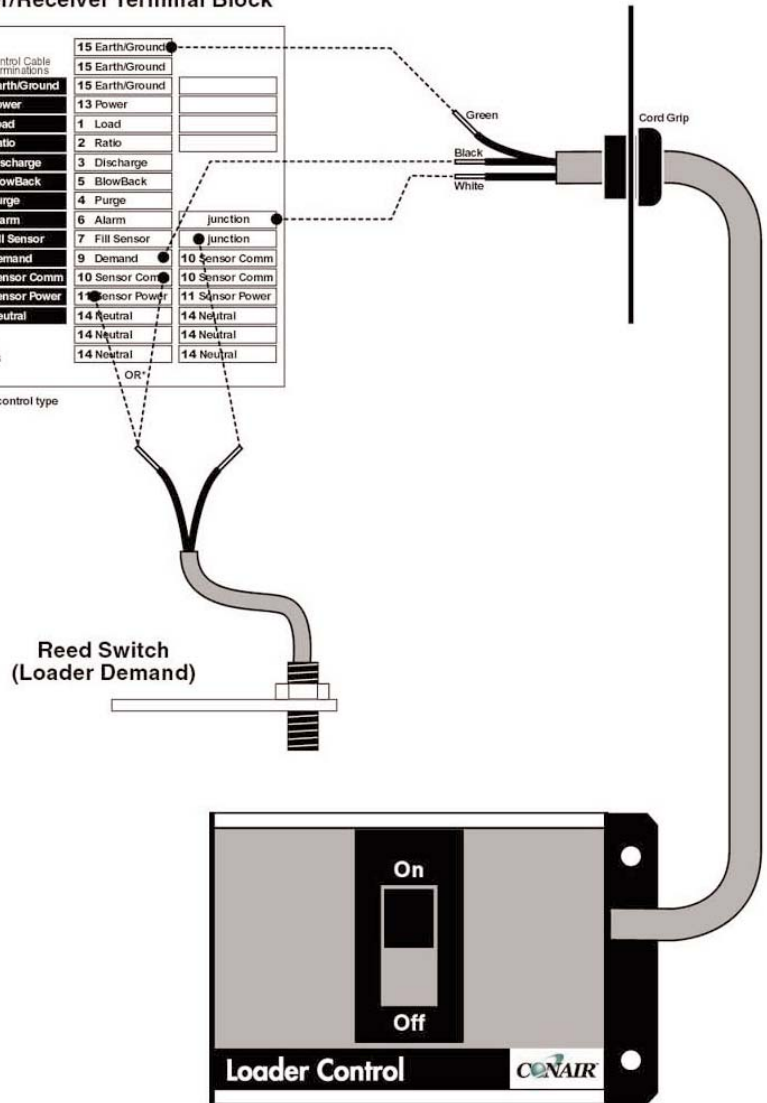

## Remote On/Off Switch Module

diagram on reverse side

### Wiring Instructions

Note: All wiring must be performed by a qualified electrician with strict adherence to local electrical codes:

1. Remove a hole plug from the top of the terminal box for the on/off switch cable. Install cable through the selected hole in the terminal box using the accompanying cord grip. Make sure that there is enough wire length inside the box to connect to the terminal block and switch.
2. Locate the loader/receiver's reed switch connections on the terminal block. One wire should be connected to #9 (Demand) and the other to either #10 (Sensor Comm) or #11 (Sensor Comm), depending on the control type. Press the adjacent terminal block lever and remove the reed switch wire from the #9 terminal. Relocate this reed switch wire to either of the "junction" terminals by pressing the adjacent lever of this terminal and inserting the wire. Check to see that it is firmly installed by tugging on it lightly.
3. Connect the green wire from the on/off switch to any one of the #15 (Earth Ground) terminals.
4. Insert the black wire from the switch into the #9 (Demand) terminal.
5. Install the white wire of the switch into the open "junction" terminal on the terminal block.

Wiring is now complete and providing all wires are firmly connected, the terminal box may now be closed.

Route the on/off switch wire neatly to the desired location, avoiding hot surfaces or moving parts. It may be mounted to any firm surface using the two holes located on its mounting tab.

### Using the Remote On/Off Switch

The on/off switch interrupts the loader or receiver's demand input, to prevent further loading. If the switch is moved to the off position during loading, the loading cycle will finish, but prevent another cycle from starting.

To test the switch:

1. Make sure that no material or any other blockage is keeping the loader/receiver's discharge flapper from closing and energize the loader/receiver.
2. With the switch in the "ON" position, the loader/receiver should operate normally.
3. Switch to the "OFF" position. The loader/receiver should complete the current loading cycle and then halt all further loading.